

Application Note:

**HFAN-09.0.4**

Rev 0; 09/02

---

---

## **NRZ Bandwidth – LF Cutoff and Baseline Wander**

---

---

MAXIM High-Frequency/Fiber Communications Group



*Maxim Integrated Products*



# NRZ Bandwidth – LF Cutoff and Baseline Wander

## 1 Introduction

A fundamental goal when designing physical-layer digital communication systems is transmission of the data signal through the system with minimum distortion. In order to accomplish this goal, it is imperative to match (as closely as possible) the system bandwidth to the bandwidth requirements of the data. The effects of limiting the high end of the system bandwidth have been documented in a previous application note ([HFAN-9.0.1 “NRZ Bandwidth – HF Cutoff vs. SNR”](#)). The purpose of this application note is to explore the effects of limiting the low end of the system bandwidth.

For various reasons it can be advantageous to block transmission of the lowest frequency (i.e., direct current) components of a signal. This is commonly done by inserting a series capacitor in the transmission path and is generally called “ac-coupling”. There are also other reasons, intentional or otherwise, that the low-frequency portion of a signal may be attenuated or blocked. This application note focuses on the effects of attenuating the low-frequency components of nonreturn-to-zero (NRZ) data signals.

## 2 NRZ Encoded Data

In order to transmit binary data, it must be encoded into a signal (e.g., an electrical or optical waveform) that is suitable for the transmission medium (e.g., copper cable, optical fiber, etc.). Of the many binary data encoding methods currently in use, nonreturn-to-zero (NRZ) is one of the most common.

In NRZ encoding, each binary digit (bit) is assigned an equal amount of time, called the bit period,  $T_b$ . During each bit period, a binary one is represented by a high amplitude, and a binary zero is represented by a low amplitude. The sequence of encoded bits is called the bit stream or data signal. Timing synchronization is maintained by a square wave signal called the bit clock. An NRZ encoded bit stream and bit clock are illustrated in Figure 1.

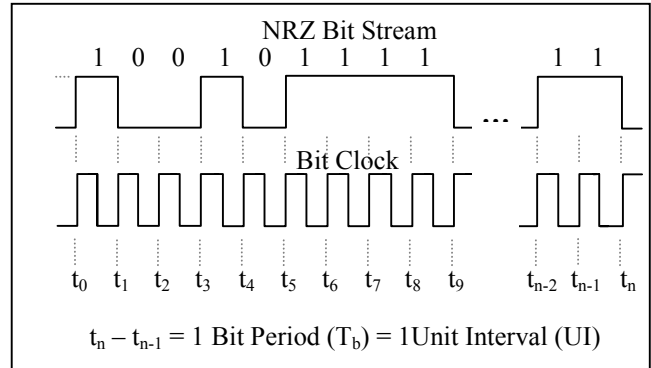

Figure 1. NRZ encoded bit stream

We have previously shown<sup>1</sup> that the power spectral density of random NRZ data can be mathematically represented by  $\alpha T_b \text{sinc}^2(T_b f)$ , where  $\text{sinc}(f)$  is defined as  $(\sin \pi f)/\pi f$ ,  $\alpha$  is a proportionality constant, and  $f$  is the frequency in Hertz. This result is illustrated in Figure 2 (note that the frequency axis is normalized to the data rate).

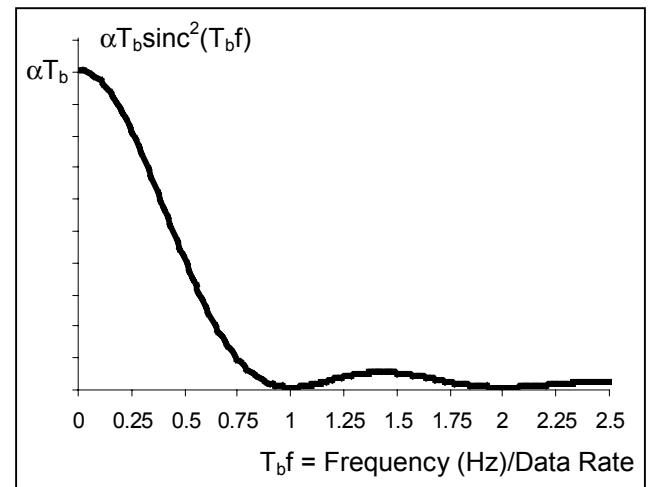

Figure 2. Power spectrum of random NRZ data

## 3 Low-Frequency (LF) Cutoff

When the low-frequency components of the random NRZ data are attenuated, the power spectrum takes on a modified form. This is illustrated by the modified power spectrum of Figure 3, where the normalized frequency,  $T_b f_c$ , represents the half-power (i.e., 3dB) frequency that is called the *low*

frequency (or LF) cutoff. A system that attenuates or blocks low frequencies and passes the higher frequencies is called a high-pass system, and, for such a system, the LF cutoff marks the defined division between the frequencies that are attenuated and the frequencies that are passed.

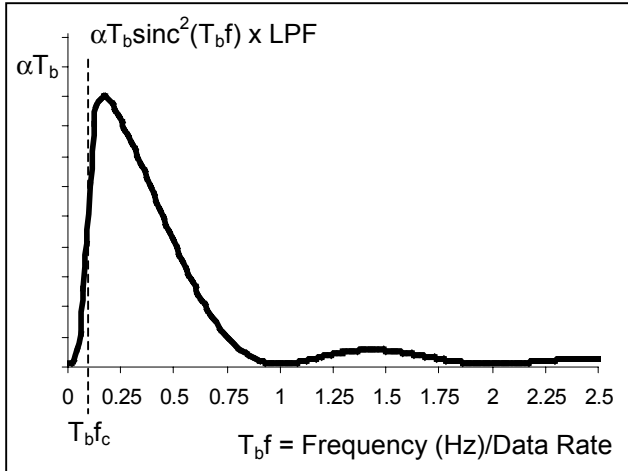

Figure 3. Power spectrum of random NRZ data

The most important measure of system performance is the bit error ratio (BER). Two of the most important factors that determine the BER are the signal-to-noise ratio (SNR) and timing jitter. (See Maxim application notes [HFAN-9.0.2 “Optical Signal-to-Noise Ratio and the Q-Factor in Fiber-Optic Communication Systems”](#) and [HFAN-4.0.4 “Jitter in Digital Communication Systems, Part 2”](#).) Clearly the loss of the low-frequency portion of the signal power will reduce the SNR and thus degrade the BER. The low-frequency cutoff can also increase the timing jitter ([HFAN-1.1 “Choosing AC-Coupling Capacitors”](#)), further degrading the BER.

There is another, more subtle effect that results from removing the low frequencies. It can also degrade the BER. This effect is called *baseline wander*.

#### 4 LF Cutoff and Baseline Wander

The purpose of this section is to show, by means of an example, what baseline wander is and how removing the low-frequency components from an NRZ bitstream cause it.

A simple example of a single-time-constant high-pass network is the ac-coupled transmission system shown in Figure 4. In this figure the time constant,  $\tau$ , of the system is equal to  $RC$ , where  $R$  is the combined source and load resistance and  $C$  is the

capacitance of the ac-coupling capacitor. Other examples can also be considered, but the analysis is similar for all high-pass systems.

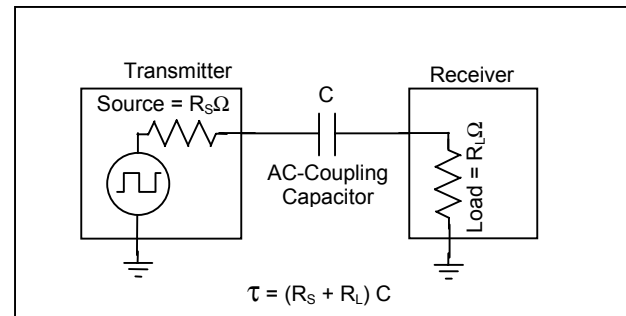

Figure 4. AC-Coupled Transmission System

We will start with the portion of a transmitted NRZ bit stream shown in Figure 5(a), which we represent mathematically as  $S_T(t)$ . In order to write an expression for  $S_T(t)$  we will use the unit step function,  $u(t)$ , which is defined as having a value of zero for  $t < 0$  and a value of one for  $t \geq 0$ , i.e.,

$$u(t) = \begin{cases} 0, & t < 0 \\ 1, & t \geq 0 \end{cases} \quad (1)$$

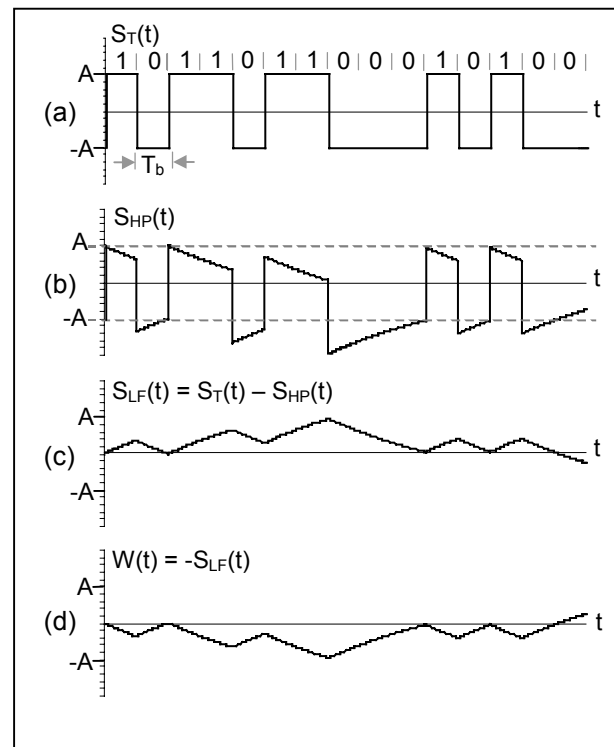

Figure 5. (a) Transmitted signal  $S_T(t)$ , (b) High-pass filtered signal  $S_{HP}(t)$ , (c) Filtered out low-frequency component of signal,  $S_{LF}(t) = S_T(t) - S_{HP}(t)$ , and (d) Baseline wander  $W(t) = -S_{LF}(t)$ .

In terms of  $u(t)$ , the expression for  $S_T(T)$  is

$$S_T(t) = Au(t) - 2Au(t - T_b) + 2Au(t - 2T_b) - 2Au(t - 4T_b) + 2Au(t - 5T_b) - \dots \quad (2)$$

where  $A$  is the peak amplitude and  $T_b$  is the bit period. Next, we recall that the step response of a single-time-constant high-pass network<sup>3</sup> is equal to  $e^{-t/\tau}$ , and using this we can write the following expression for the high-pass filtered signal,  $S_{HP}(t)$ :

$$S_{HP}(t) = Au(t)e^{-\frac{t}{\tau}} - 2Au(t - T_b)e^{-\frac{(t-T_b)}{\tau}} + 2Au(t - 2T_b)e^{-\frac{(t-2T_b)}{\tau}} - 2Au(t - 4T_b)e^{-\frac{(t-4T_b)}{\tau}} + 2Au(t - 5T_b)e^{-\frac{(t-5T_b)}{\tau}} - \dots \quad (3)$$

which is plotted in Figure 5(b). It is also interesting to note that the low-frequency portion of the original signal (that is filtered out) is just equal to the original signal,  $S_T(t)$ , minus the high-pass filtered signal,  $S_{HP}(t)$ , i.e.,

$$S_{LF}(t) = S_T(t) - S_{HP}(t) = Au(t)(1 - e^{-\frac{t}{\tau}}) - 2Au(t - T_b)(1 - e^{-\frac{(t-T_b)}{\tau}}) \dots \quad (4)$$

This result is illustrated in Figure 5(c). Note that  $(1 - e^{-t/\tau})$  in equation (4) is the step response of a single-time-constant low-pass network<sup>3</sup>. Finally, we see that the average value (i.e., the midpoint between the high and low levels) of the high-pass signal shown in Figure 5(b) changes with time due to the subtraction of the low frequencies. This variation in the average midpoint is defined as *baseline wander*. The baseline wander,  $W$ , is equal to the negation of  $S_{LF}(t)$ , i.e.,

$$W(t) = -S_{LF}(t) = -Au(t)(1 - e^{-\frac{t}{\tau}}) + 2Au(t - T_b)(1 - e^{-\frac{(t-T_b)}{\tau}}) \dots \quad (5)$$

Figure 5(d) is a plot of the baseline wander.

## 5 Baseline Wander Observations

From the example of the preceding section, we can make a number of important observations regarding baseline wander, but first we need to define a new term. We will define the *cumulative bit difference (CBD)* as the difference between the number of

transmitted zeros and the number of transmitted ones. This definition can be mathematically written as:

$$CBD[n] = N_0[n] - N_1[n] \quad (6)$$

where  $CBD[n]$  is the cumulative bit difference at the  $n^{\text{th}}$  bit of the pattern,  $N_0[n]$  is the cumulative number of zeros in the pattern up to the  $n^{\text{th}}$  bit, and  $N_1[n]$  is the cumulative number of ones in the pattern up to the  $n^{\text{th}}$  bit. Using this definition we make the following observations:

- (1) The magnitude of the baseline wander at the  $n^{\text{th}}$  bit in an NRZ pattern is determined by two factors: (a) the cumulative bit difference at the  $n^{\text{th}}$  bit, and (b) the magnitude of the low-frequency cutoff. This means that baseline wander can be controlled by forcing a constant CBD and/or by reducing the frequency of the cutoff.
- (2) The baseline wander changes the fastest when there are sequences of consecutive identical digits (CIDs), and this also causes the fastest possible change in the cumulative bit difference.
- (3) Long strings of CIDs are not the only source of baseline wander. The cumulative bit difference, and hence the baseline wander, changes with any imbalance between the number of ones and zeros.
- (4) The magnitude of the baseline wander is determined entirely by the CBD only when the CBD is computed over a number of bit periods that constitute a small fraction of one time constant. For example, the droop in baseline wander over 0.01 time constants is approximately 0.01, so if we compute  $CBD[n]$  only using the previous  $0.01\tau/T_b$  bits, then the baseline wander in this local region of the pattern will be almost entirely determined by this “local”  $CBD[n]$ . However, if we compute  $CBD[n]$  over a period that is longer than a fraction of the time constant, then the magnitude of the baseline wander will be greatly effected by droop instead of the “long-term” CBD. For example, a long string of CIDs will produce a large change in baseline wander, but if it is followed by a long string of alternating ones and zeros, the baseline wander will eventually droop back to near zero (even though the alternating one-zero sequence has little effect on the CDB).

## 6 Estimating Baseline Wander

As noted in the above observations, the magnitude of the baseline wander is determined by the cumulative bit difference in the NRZ waveform and by the position of the low frequency cutoff. We also note that the change in the baseline wander over the time of a single bit or series of CIDs is an exponential function and therefore non-linear. This non-linearity means that, in general, the overall change in baseline wander may be different for the same cumulative bit difference depending on the ordering of the bits in the pattern, as illustrated in Figure 6). Calculating and/or plotting the exact value of the baseline wander using exponential functions is possible (as in the example of Figure 5), but can be tedious and time consuming for long data sequences.

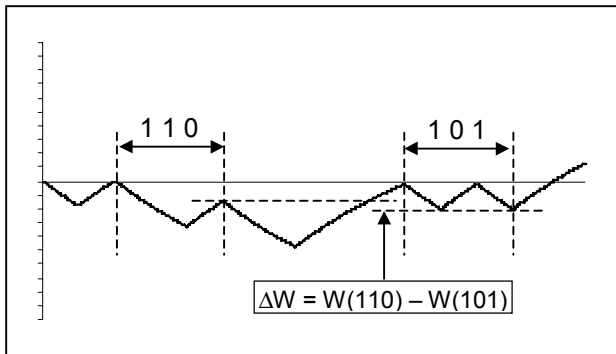

Figure 6. Derived from Figure 5(d). The difference in baseline wander for a 110 sequence versus a 101 sequence.

If we make the simplifying assumption that the rate of change of the baseline wander is constant (i.e., linear), then estimation of the baseline wander can be greatly simplified. This is because, for linear baseline wander, the offset accumulates the same (adds linearly) regardless of the particular pattern arrangement. Therefore we can calculate the approximate baseline wander as a function of the local cumulative bit difference (without regard to the exact pattern). Using this method of approximation, the estimated baseline wander can be calculated by substituting the linear approximation for the exponential function in equation (5) as follows:

$$W(t) = -Au(t)\left(1 - \frac{t}{T_b}\right) + 2Au(t - T_b)\left(1 - \frac{t - T_b}{\tau}\right) \dots (7)$$

The major simplification afforded by this method is that the summations over the entire bit sequence in equation (7) can be reduced to the simple form

$$W(t) = CBD[n] \times \frac{T_b}{\tau} \quad (8)$$

as long as  $CBD[n]$  is calculated using the “local” CBD criteria outlined in observation 4 of the previous section.

The accuracy of the linear approximation is a function of the system time constant and the time period over which the estimate accuracy must be maintained. The relationship between the exponential function and its linear approximation (as a function of time) is illustrated in Figure 7 and tabulated in Table I. For example, from Table I we can see that the difference between the linear approximation and the actual exponential function is less than 0.01 as long as the ratio between the time period in question and the system time constant is less than 0.145.

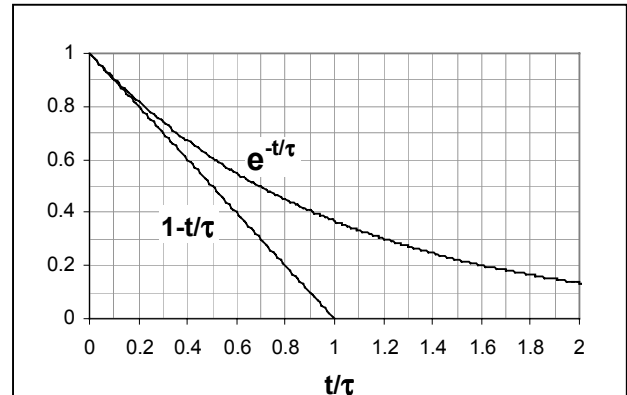

Figure 7. Linear approximation of  $e^{-t/\tau}$

TABLE I. LINEAR APPROXIMATION OF  $e^{-t/\tau}$

$t/\tau$	$e^{-t/\tau}$	$1 - t/\tau$	$\Delta$
0.045	0.95599	0.955	0.001
0.102	0.90303	0.898	0.005
0.145	0.86502	0.855	0.010

As an example, we will calculate the necessary system time constant (and corresponding LF cutoff) for accurate linear approximation of baseline wander. Suppose that we are transmitting data at 1Gbps and the maximum CID length is 72 bits. In this case the time for the maximum CID length is  $72\text{bits} \times 1\text{ns/bit} = 72\text{ns}$ . Assume that we wish to keep the estimation error (the difference between the actual and estimated baseline wander) below 0.001 over the maximum CID length. From Table I, we need  $t/\tau = 0.045$  for 0.001 estimation accuracy, so  $\tau$

$= 72\text{ns}/0.045 = 1.6\mu\text{s}$ . If we assume a  $50\Omega$  source and  $50\Omega$  load, then  $C = \tau / R = 1.6\mu\text{s}/100\Omega = 16\text{nF}$ . The low-frequency cutoff is  $f_c = 1/2\pi\tau \text{ Hz} \approx 100 \text{ kHz}$ . Therefore, in this example, the difference between the linear approximation and the actual value will be less than or equal to 0.001 for all CID lengths if we choose an ac-coupling capacitance of  $>16\text{nF}$ , which corresponds to a low-frequency cutoff of  $<100 \text{ kHz}$ .

Next, we can apply the approximation method to estimate the baseline wander of the data sequence shown in Figure 5(a). This data sequence consists of the following 15 bits: 101101100010100. There are eight zeros and seven ones, so  $\text{CBD}[15] = +1$ . The longest CID length is 3, so, if we assume a data rate of 1Gbps, the CID time period is 3ns. Using the method outlined in the paragraph above, we determine that we can use the linear approximation with excellent accuracy as long as the system time constant is greater than 67ns (equivalent to a LF cutoff of 2.4MHz). We also note that (from section 5, observation 4), if  $0.01\tau / T_b >$  the sequence length of 15 bits, then we can use the simplified expression of equation (8) to obtain the baseline wander. Using this constraint,  $0.01\tau / 1\text{ns} > 15$  gives a time constant requirement of  $>1.5\mu\text{s}$  (equivalent LF cutoff of  $< 106\text{kHz}$ ). Therefore, if we assume the time constant is  $1.5\mu\text{s}$ , we can accurately use equation (8) to determine that  $W(t) = +1 \times 1\text{ns}/1.5\mu\text{s} = 670\mu\text{V}$ .

## 7 Effects of Baseline Wander

Baseline wander in high-frequency waveforms may be difficult to detect and quantify. This is due to the fact that most of the methods of observing the signal quality of the transmitted waveform involve the use of digital sampling oscilloscopes that are optimized to display high-frequency signals, and the effects of the low-frequency baseline wander on the oscilloscope display can be very subtle, or even non-existent. Figure 8 is an example of an eye diagram displayed on a digital sampling oscilloscope. The baseline wander is evidenced in this eye diagram by the extra dots scattered above and below the main lines, indicating occasional sample “hits” at higher or lower levels than the nominal.

Baseline wander can cause an increase in bit errors due to sub-optimum sampling in the receiver. The optimum receiver sampling threshold (for minimum BER) is determined by the modulation amplitude as well as the difference between the noise at the one

and zero levels. The decision circuit is usually adjusted to achieve the optimum vertical threshold. Baseline wander causes duty-cycle distortion, which effectively moves waveform up and down in the vertical dimension. This vertical movement relative to the decision threshold can cause the sub-optimum sampling. The result is an increased probability of incorrectly detecting the received bits, which can increase the bit error ratio (BER).

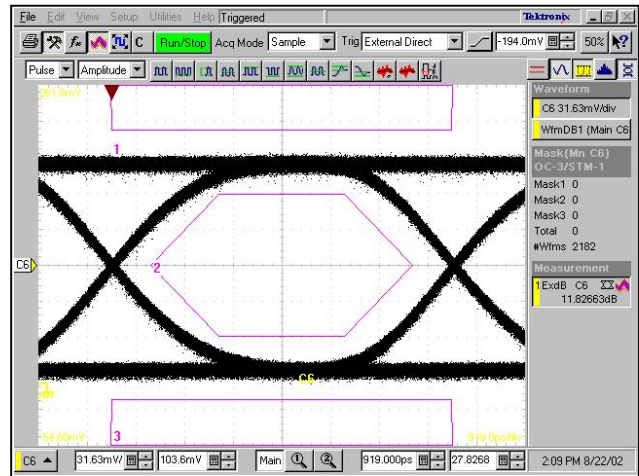

Figure 8. Eye diagram displayed on a digital sampling oscilloscope. Scattered dots above and below the main lines are evidence of baseline wander.

## 8 Conclusions

Baseline wander is a slow variation in the average of a signal waveform. It is caused by attenuation of the low-frequency content of the signal and can result in increased jitter and BER degradation.

Baseline wander can be controlled by designing the system to have a sufficiently small low-frequency cutoff, by ensuring that there are approximately equal numbers of ones and zeros in all segments of the data pattern, and by clever coding of the data to reduce low frequency components. For example, many standard communication protocols (e.g., SONET, Ethernet, Fibre Channel, etc.) use techniques such as data scrambling and 8b/10b encoding to control the cumulative bit difference and limit low-frequency content.

The magnitude of the baseline wander at any point in the data pattern can be accurately estimated by using a linear approximation to the exponential function. This approximation is valid when the ratio between the bit period and the system time constant is sufficiently small.

---

<sup>1</sup> Maxim Integrated Products application note HFAN-9.0.1 “NRZ Bandwidth – HF Cutoff vs. SNR,” <http://pdfserv.maxim-ic.com/arpdf/AppNotes/1hfan901.pdf>.

<sup>2</sup> M.E. Van Valkenburg, *Network Analysis*, 3<sup>rd</sup> Ed., Englewood Cliffs, New Jersey: Prentice Hall 1974, pp. 174.

<sup>3</sup> A.S. Sedra and K.C. Smith, *Microelectronic Circuits*, New York, N.Y.:CBS College Publishing 1982, pp.60-61.